

	GOTOP GAM-2107-MT
	Ultra High Sensitivity and Low Power GPS Antenna Module

General Description

The GOTOP GAM-2107-MT is a complete GPS engine module that features super sensitivity, ultra low power and small form factor. The GPS signal is applied to the antenna input of module, and a complete serial data message with position, velocity and time information is presented at the serial interface with NMEA protocol or custom protocol.

Its -165dBm tracking sensitivity extends positioning coverage into place like urban canyons and dense foliage environment where the GPS was not possible before. The small form factor and low power consumption make the module easy to integrate into portable device like PNDs, mobile phones, cameras and vehicle navigation systems.

Applications

- LBS (Location Based Service)
- PND (Portable Navigation Device)
- Vehicle navigation system
- Mobile phone



Figure 1: GAM-2107-MT Top View

Features

- Build on high performance, low-power MTK3339chipset
- Ultra high sensitivity: -165dBm
- Extremely fast TTFF at low signal level
- Built in high gain LNA
- Low power consumption: Max 20mA@3.3V
- NMEA-0183 compliant protocol or custom protocol
- Operating voltage: 2.8V ---4.3V
- Operating temperature range: -40 to 85°C
- Patch Antenna Size:20(w)mmX6.0(d)mmX4.0(h)mm
- Small form factor: 21x7.0x6.0mm
- RoHS compliant (Lead-free)

Performance Specification

Parameter	Specification	
Receiver Type	L1 frequency band, 22tracking/66acquisition-channel	
Sensitivity	Tracking	-165dBm
	Acquisition	-163dBm(hot)
		-148dBm(cold)
Accuracy	Position	5m CEP without SA
	Velocity	0.1m/s without SA

Acquisition Time	Cold Start	38s
	Warm Start	35s
	Hot Start	1s
	Re-Acquisition	<1s
Power Consumption	Tracking	20mA @3.3V Vcc
	Acquisition	20mA
	Sleep/Standby	TBD
NavigationDataUpdate Rate	1Hz	
Operational Limits	Altitude	Max 18,000m
	Velocity	Max 515m/s
	Acceleration	Less than 4g

Interfaces Configuration

Power Supply: Regulated power for the GAM-2107-MT is required. The input voltage Vcc should be 3.3V \pm 10%, maximum, current is no less than 30mA. Suitable decoupling must be provided by external decoupling circuitry.

UART Ports: The module supports two full duplex serial channels UART. All serial connections are at 3.0V CMOS logic levels, if need different voltage levels, use appropriate level shifters. The baud rate of both serial ports are fully programmable, the data format is however fixed: X, N, 8, 1, i.e. X baud rate, no parity, eight data bits and one stop bit, no other data formats are supported, LSB is sent first. The modules default

baud rate is set up 9600bps, however, the user can change the default baud rate to any value from 4800 bps to 115kbps. UART is used e.g. for booting and NMEA interface.

CON1 Pin Description

Pin No.	Pin name	I/O	Description	Remark
1	V_BAT	I	RTC Battery Input	
2	TXD	O	UART Serial Data Output	
3	RXD	I	UART Serial Data Input	
4	Vcc	I	Module Power Supply	
5	GND	G	Ground	

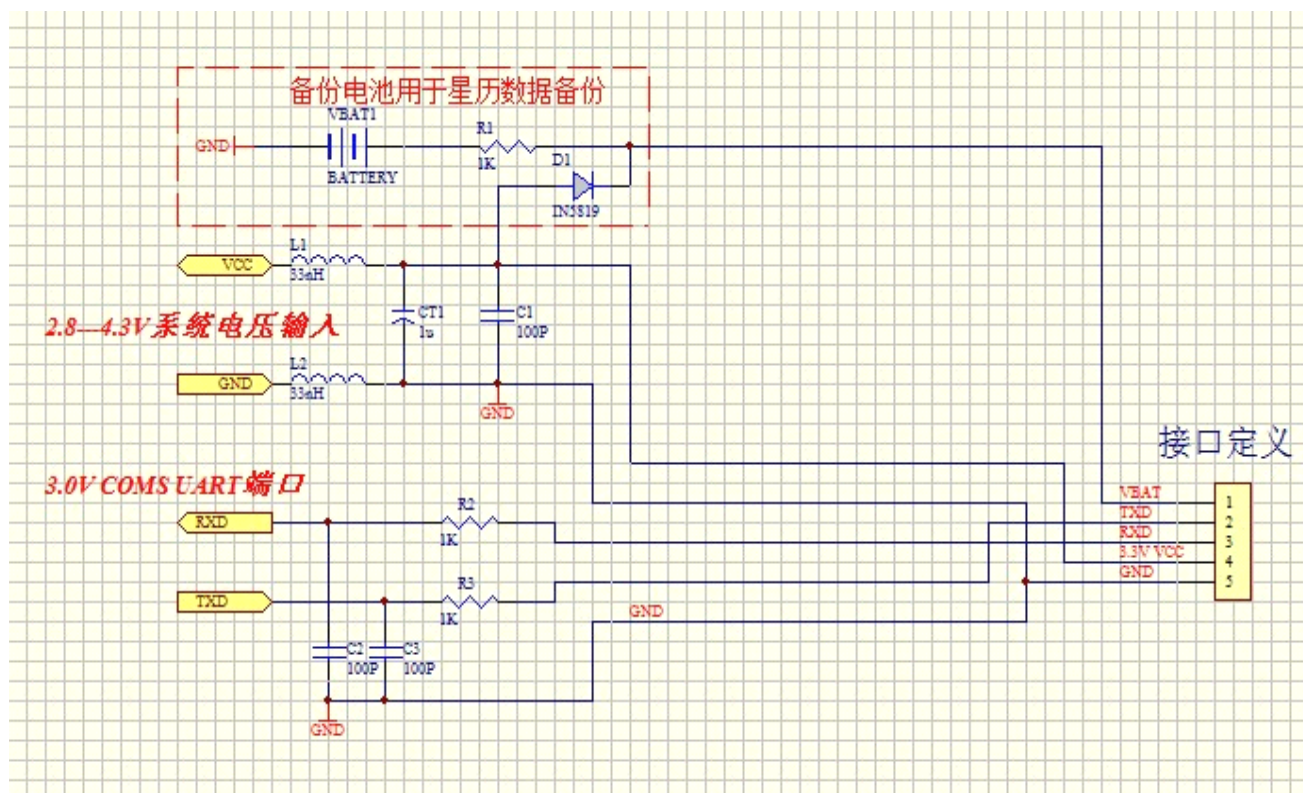

Absolute Maximum Rating

Parameter	Symbol	Min	Max	Units
Power Supply				
Power Supply Volt.	V _{cc}	2.8	4.3	V
Input Pins				
Input Pin Voltage I/O	RXD/TXD	-0.3	3.0	V
Input Pin Voltage I/O	V_BAT	-0.3	3.6	V
Environment				
Storage Temperature	T _{stg}	-40	125	°C
PeakReflow Soldering Temperature	T _{peak}		260	°C
Humidity			95	%

Note: Absolute maximum ratings are stress ratings only, and functional operation at the maxims is not guaranteed. Stress beyond the limits specified in this table may affect device reliability or cause permanent damage to the device. For functional operating conditions, refer to the operating conditions tables as follow.

Operating Conditions

Parameter	Symbol	Condition	Min	Typ	Max	Units
-----------	--------	-----------	-----	-----	-----	-------

Power supply voltage	V _{CC}		2.8	3.3	4.3	V
Power supply voltage ripple	V _{CC_PP}	V _{CC} =3.3V			20	mV
Consumption current	I _{CC}	V _{CC} =3.3V		20	20	mA
Input high voltage	V _{IH}		0.7xV _{CC}		V _{CC} +1.0	V
Input low voltage	V _{IL}		-0.3		0.3xV _{CC}	V
Output high voltage	V _{OH}		0.8xV _{CC}		V _{CC}	V
Output low voltage	V _{OL}		0		0.2xV _{CC}	V
Operating temperature	Topr		-40		85	°C

NMEA 0183 Protocol

The NMEA protocol is an ASCII-based protocol, Records start with a \$ and with carriage return/line feed. GPS specific messages all start with \$GPxxx where xxx is a three-letter identifier of the message data that follows. NMEA messages have a checksum, which allows detection of corrupted data transfers.

The Label Jet GAM-2107-MT supports the following NMEA-0183 messages: GGA, GSA, GSV, VTG, GLL and RMC.

Table 1: NMEA-0183 Output Messages

NMEA Record	DESCRIPTION
-------------	-------------

GGA	Global positioning system fixed data
GLL	Geographic position—latitude/longitude
GSA	GNSS DOP and active satellites
GSV	GNSS satellites in view
RMC	Recommended minimum specific GNSS data
VTG	Course over ground and ground speed

GGA-Global Positioning System Fixed Data

Table 2 contains the values of the following example:

\$GPGGA, 161229.487,3723.2475,N, 12158.3416,W, 1,07,1.0,9.0,M.0000*18

Table 2: GGA Data Format

Name	Example	Units	Description
Message ID	\$GPGGA		GGA protocol header
UTC Position	161229.487		hhmmss.sss
Latitude	3723.2457		ddmm.mmmm
N/S indicator	N		N=north or S=south
Longitude	12158.3416		dddmm.mmmm
E/W Indicator	W		E=east or W=west
PositionFix Indicator	1		See Table 2-1
Satellites Used	07		Range 0 to 12

HDOP	1.0		Horizontal Dilution of Precision
MSL Altitude	9.0	meters	
Units	M	meters	
Geoids Separation		meters	
Units	M	meters	
Age of Diff.Corr.		second	Null fields when DGPS is not Used
Diff.Ref.Station ID	0000		
Checksum	*18		
<CR> <LF>			End of message termination

Table 2-1: Position Fix Indicators

Value	Description
0	Fix not available or invalid
1	GPS SPS Mode, fix valid
2	Differential GPS, SPS Mode, fix valid
3	GPS PPS Mode, fix valid

GLL-Geographic Position – Latitude/Longitude

Table 3 contains the values of the following example:

\$GPGLL , 3723.2475, N,12158.3416, W,161229.487, A*2C.

Table 3: GLL Data Format

Name	Example	Units	Description
------	---------	-------	-------------

Message ID	\$GPGLL		GLL protocol header
Latitude	3723.2475		ddmm.mmmm
N/S Indicator	N		N=north or S=south
Longitude	12158.3416		dddmm.mmmm
E/W Indicator	W		E=east or W=west
UTC Position	161229.487		hhmmss.sss
Status	A		A=data valid or V=data not valid
Checksum	*2C		
<CR> <LF>			End of message termination

GSA-GNSS DOP and Active Satellites

Table 4 contains the values of the following example:

\$GPGSA , A, 3, 07, 02, 26,27, 09, 04,15, , , , , , 1.8,1.0,1.5*33.

Table 4: GSA Data Format

Name	Example	Units	Description
Message	\$GPGSA		GSA protocol header
Mode 1	A		See Table 4-2
Mode 2	3		See Table 4-1
Satellite Used	07		Sv on Channel 1
Satellite Used	02		Sv on Channel 2

...
Satellite Used			Sv on Channel 12
PDOP	1.8		Position Dilution of Precision
HDOP	1.0		Horizontal Dilution of Precision
VDOP	1.5		Vertical Dilution of Precision
Checksum	*33		
<CR> <LF>			End of message termination

Table 4-1: Mode 1

Value	Description
1	Fix not available
2	2D
3	3D

Table 4-2: Mode 2

Value	Description
M	Manual-forced to operate in 2D or 3D mode
A	Automatic-allowed to automatically switch 2D/3D

GSV-GNSS Satellites in View

Table 5 contains the values of the following example:

\$GPGSV , 2, 1, 07, 07, 79,048, 42, 02, 51,062, 43, 26, 36,256, 42, 27, 27, 138,42*71

\$GPGSV, 2, 2, 07, 09, 23,313, 42, 04, 19, 159, 41, 15,12,041, 42*41.

Table 5: GGA Data Format

Name	Example	Units	Description
Message ID	\$GPGSV		GSV protocol header
Number of Message	2		Range 1 to 3
Message Number	1		Range 1 to 3
Satellites in View	07		
Satellite ID	07		Channel 1(Range 1 to 32)
Elevation	79	degrees	Channel 1(Maximum 90)
Azinmuth	048	degrees	Channel 1(True, Range 0 to 359)
SNR(C/NO)	42	dBHz	Range 0 to 99,null when not tracking
...			...
Satellite ID	27		Channel 4(Range 1 to 32)
Elevation	27	degrees	Channel 4(Maximum 90)
Azimuth	138	degrees	Channel 4(True, Range 0 to 359)
SNR(C/NO)	42	dBHz	Range 0 to 99, null when not tracking
Checksum	*71		
<CR> <LF>			End of message termination

Depending on the number of satellites tracked multiple messages of GSV data may be required.

RMC-Recommended Minimum Specific GNSS Data

Table 6 contains the values of the following example:

\$GPRMC, 161229.487, A, 3723.2475, N, 12158.3416, W, 0.13,309.62, 120598,, *10

Table 6: RMC Data Format

Name	Example	Units	Description
Message ID	\$GPRMC		RMC protocol header
UTS Position	161229.487		hhmmss.sss
Status	A		A=data valid or V=data not valid
Latitude	3723.2475		ddmm.mmmm
N/S Indicator	N		N=north or S=south
Longitude	12158.3416		dddmm.mmmm
E/W Indicator	W		E=east or W=west
Speed Over Ground	0.13	Knots	
Course Over	309.62	Degrees	True
Ground			
Date	120598		Dummy
Magnetic variation		Degrees	E=east or W=west
Checksum	*10		

<CR> <LF>			End of message termination
-----------	--	--	----------------------------

VTG-Course Over Ground and Ground Speed

Table 7 contains the values of the following example:

\$GPVTG, 309.62, T, M, 0.13, N, 0.2, K*6E

Table 7: VTG Data Format

Name	Example	Units	Description
Message ID	\$GPVTG		VTG protocol header
Course	309.62	Degrees	Measured heading
Reference	T		True
Course		Degrees	Measured heading
Reference	M		Magnetic
Speed	0.13	Knots	Measured horizontal speed
Units	N		Knots
Speed	0.2	Km/hr	Measured horizontal speed
Units	K		Kilometer per hour
Checksum	*6E		
<CR> <LF>			End of message termination

©Copyright 2012 Gotop Technology Co., Ltd. All Right Reserved

The information contained herein is subject to change without notice.

Gotop Technology Co. , LTD

Add:Room 603 Zhantao Technology Building,Minzhi Road,Xinniu Communnity,Minzhi Street,Baoan District,ShenZhen City China.

Phone: 13926505646 23804156

fax: 86-755-23804155

N 22° 32' 17", E 114° 07' 07"

<http://www.voosoo.cn>

Not to be reproduced in whole or part for any purpose without written permission of Gotop Technology Inc ('Gotop'). Information provided by Gotop is believed to be accurate and reliable. These materials are provided by Gotop as a service to its customers and may be used for informational purposes only. Gotop assumes no responsibility for errors or omissions in these materials, nor for its use. Gotop reserves the right to change specification at any time without notice.

These materials are provides 'as is' without warranty of any kind, either expressed or implied, relating to sale and/or use of Gotop products including liability or warranties relating to fitness for a particular purpose, consequential or incidental damages, merchantability, or infringement of any patent, copyright or other intellectual property right. Gotop further does not warrant the accuracy or completeness of the information, text, graphics or other items contained within these materials. Gotop shall not be liable for any special, indirect, incidental, or consequential damages, including without limitation, lost revenues or lost profits, which may result from the use of these materials. Gotop products are not intended for use in medical, life-support devices, or applications involving potential risk of death, personal injury, or severe property damage in case of failure of the product.