

## General Description

The Gotop GT-1010-MT is a complete GPS engine module that features super sensitivity, ultra low power and small form factor. The GPS signal is applied to the antenna input of module, and a complete serial data message with position, velocity and time information is presented at the serial interface with NMEA protocol or custom protocol.

Its  $-165\text{dBm}$  tracking sensitivity extends positioning coverage into place like urban canyons and dense foliage environment where the GPS was not possible before. The small form factor and low power consumption make the module easy to integrate into portable device like PNDs, mobile phones, cameras and vehicle navigation systems.

## Applications

- LBS (Location Based Service)
- PND (Portable Navigation Device)
- Vehicle navigation system
- Mobile phone



**Figure 1: GT-1010-MT Top View**

## Features

- Build on high performance, low-power MTK3339 chipset
- Ultra high sensitivity:  $-165\text{dBm}$
- Extremely fast TTFF at low signal level
- Built in high gain LNA
- Low power consumption: Max 16mA @ 3.3V
- NMEA-0183 compliant protocol or custom protocol
- Operating voltage: 2.8V to 4.3V
- Operating temperature range:  $-40\text{ to }85^\circ\text{C}$
- SMD type with stamp holes
- Small form factor: 9.6x9.6x2.0mm
- RoHS compliant (Lead-free)

## Performance Specification

Parameter	Specification
Receiver Type	L1 frequency band, 22tracking/66acquisition-channel
Sensitivity	Tracking -165dBm Acquisition -163dBm(hot) -148dBm(cold)
Accuracy	Position 5m CEP without SA Velocity 0.1m/s without SA Timing (PPS) 1mS RMS
Acquisition Time	Cold Start 38s Warm Start 35s Hot Start 1s Re-Acquisition <1s
Power Consumption	Tracking 16mA @3.3V Vcc Acquisition 14mA Sleep/Standby TBD
NavigationDataUpdate Rate	1Hz
Operational Limits	Altitude Max 18,000m Velocity Max 515m/s Acceleration Less than 4g

## Interfaces Configuration

**Power Supply:** Regulated power for the GT-1010-MT is required. The input voltage Vcc should be 3.3V  $\pm$ 10%, maximum, current is no less than 16mA. Suitable decoupling must be provided by external decoupling circuitry.

**UART Ports:** The module supports two full duplex serial channels UART\_A and UART\_B. All serial connections are at 3V CMOS logic levels, if need different voltage levels, use appropriate level shifters. The baud rate of both serial ports are fully programmable, the data format is however fixed: X, N, 8, 1, i.e. X baud rate, no parity, eight data bits and one stop bit, no other data formats are supported, LSB is sent first. The modules default baud rate is set up 9600bps, however, the user can change the default baud rate to any value from 4800 bps to 115kbps. UART\_A is used e.g. for booting and NMEA interface. UART\_B can be utilized for UBP protocol.

**Antenna:** The GT-1010-MT GPS receiver is designed for supporting the active antenna or passive antenna connected with pin RF\_IN. The gain of active antenna should be no less than 15dB. The maximum noise figure should be no more than 2.5dB and output impedance is at 50 Ohm.

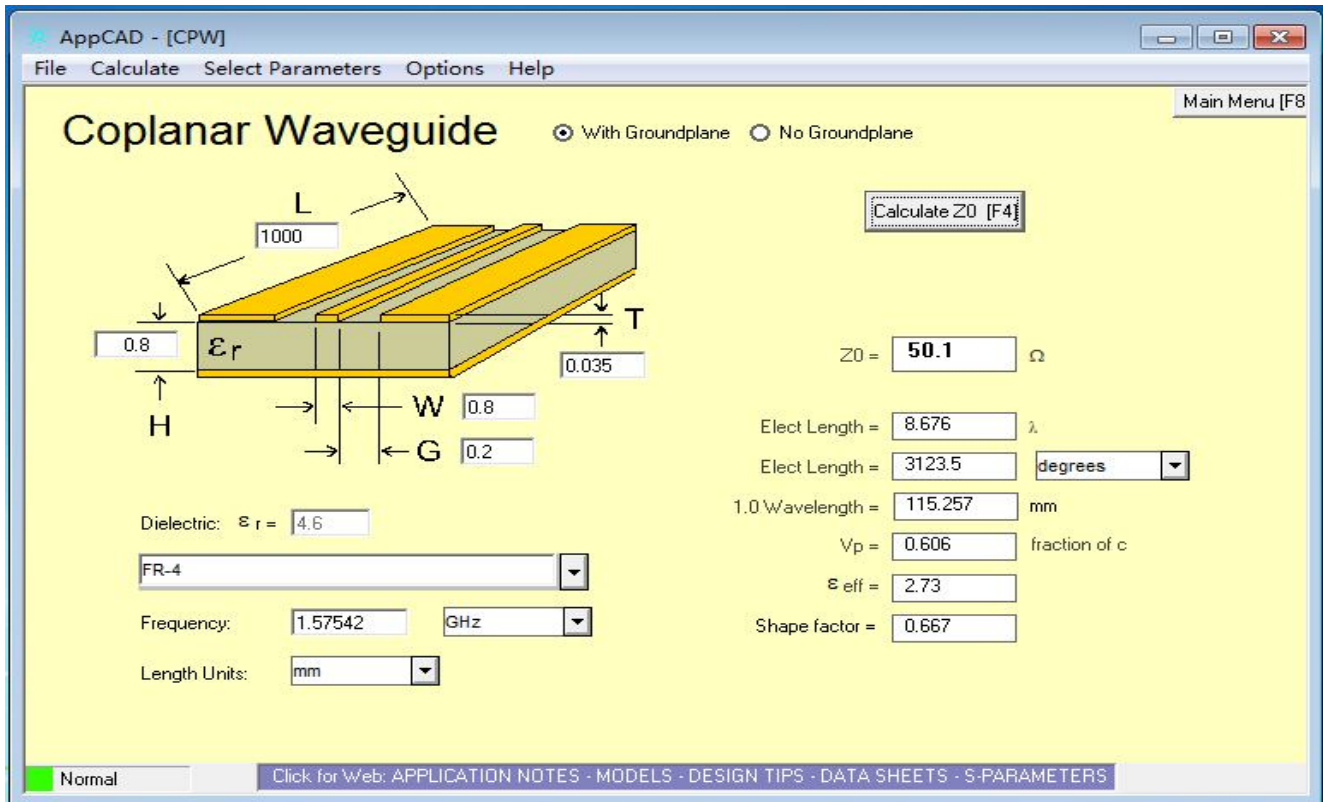

**Backup Battery Power:** In case of a power failure on pin Vcc, real-time clock and backup RAM are supplied through pin VBAT. This enables the GT-1010-MT GPS Receiver to recover from power failure with either a hot start or a warm start (depending on the duration of Vcc outage). If no Backup Battery is connected, the receiver performs a cold start upon powered up.

### Pin Description

Pin No.	Pin name	I/O	Description	Remark
1	Vcc	I	Module Power Supply	
2	VBAT	I	RTC Battery Input	
3	VCC_ANT	I	Antennabiaspower supply input .	
4	GND	G	Ground	
5	GND	G	Ground	
6	RF_IN	I	GPS Signal Input	
7	GND	G	Ground	
8	GND	G	Ground	
9	GND	G	Ground	
10	GND	G	Ground	
11	GPIO9	I	Reserved forfuture usage, leave floating	
12	RST	I	Module Reset (Active Low)	Leave Open in not used
13	GPIO9	I	Reserved forfuture usage, leave floating	
14	GND	G	Ground	
15	TXA	O	UARTSerialDataOutput ,Pull up (75KΩ) if not used	
16	RXA	I	UARTSerialDataInput ,Pull up (75KΩ) if not used	
17	TIMER	O	Powercontroloutput (open drain)usedtocontrolextern	

			al VDD switch. When not usedconnecttoGround externally.	
18	GND	G	Ground	
19	GND	G	Ground	
20	PPS	O	TimePulse(1 PPS)	LeaveOpen innotused
21	WAKEUP	O	2.8Vpoweroutputforoptional control of external LNA bias switch, active high = LNA bias on. Max load current drain 2 mA. Can be leftunconnected when not used.	
22	32K/DR_INT	O	Wakeuptinterrupt (DR_INT default), PD. Can be left unconnected when not used.Optionally 32678 Hz RTC clock output	
23	UI_FIX	O	Fixindicatoroutput(default) . Can be left unconnected when not used. GPIO6	
24	GND	G	Ground	
25	TXB	O	UART Serial DataOutput1	LeaveOpen in not used
26	RXB	I	UART Serial Data Input 1	Pull up if not used
27	EINT1	O	Standby Mode control input (not supported).Can be left unconnected when not used.GPIO13	
28	GND	G	Ground	

**Pin Assignment**

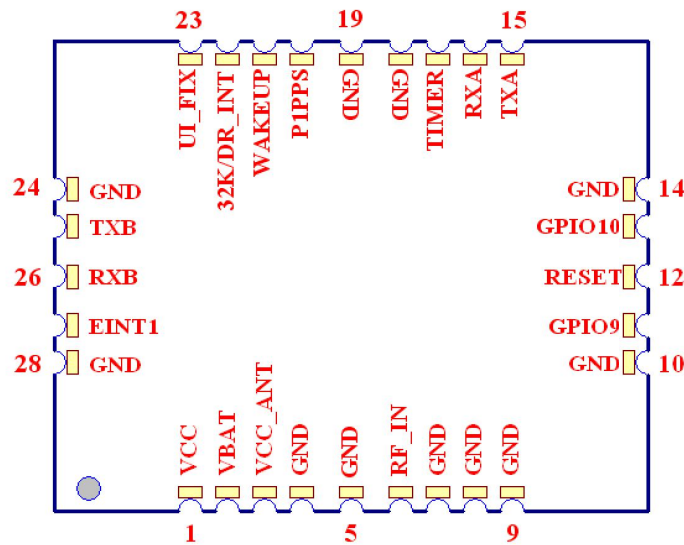

**Figure 2: GT-1010-MT Pin Package**

**Mechanical Specification**

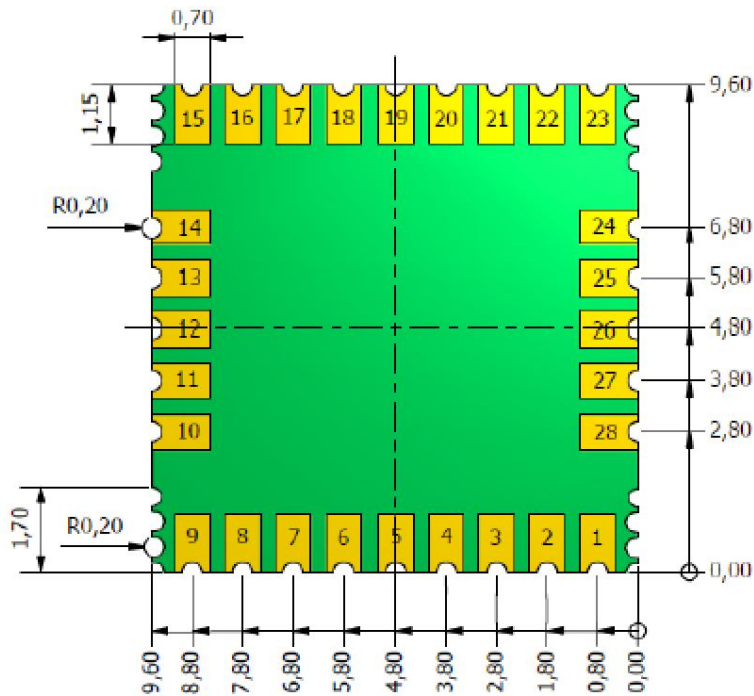

**Figure 3: GT-1010-MT Dimensions**

## Absolute Maximum Rating

Parameter	Symbol	Min	Max	Units
Power Supply				
Power Supply Volt.	Vcc	2.8	4.3	V
Input Pins				
Input Pin Voltage I/O	RST	-0.3	3.6	V
Input Pin Voltage I/O	UART	-0.3	3.6	V
Backup Battery	VBAT	2.0	3.6	V
Environment				
Storage Temperature	Tstg	-40	125	°C
PeakReflow Soldering Temperature	Tpeak		260	°C
Humidity			95	%

Note: Absolute maximum ratings are stress ratings only, and functional operation at the maxims is not guaranteed. Stress beyond the limits specified in this table may affect device reliability or cause permanent damage to the device. For functional operating conditions, refer to the operating conditions tables as follow.

## Operating Conditions

Parameter	Symbol	Condition	Min	Typ	Max	Units
Power supply voltage	Vcc		2.8	3.3	4.3	V
Powersupplyvoltagegeripple	Vcc_PP	Vcc=3.0V			30	mV
Consumption current	Icc	Vcc=3.0V		16	14	mA
Input high voltage	V <sub>IH</sub>		0.7xVcc		Vcc+1.0	V

Input low voltage	$V_{IL}$		-0.3		$0.3 \times V_{cc}$	V
Output high voltage	$V_{OH}$		$0.8 \times V_{cc}$		$V_{cc}$	V
Output low voltage	$V_{OL}$		0		$0.2 \times V_{cc}$	V
Operating temperature	$T_{opr}$		-40		85	°C

## Software Protocol

### NMEA 0183 Protocol

The NMEA protocol is an ASCII-based protocol, Records start with a \$ and with carriage return/line feed. GPS specific messages all start with \$GPxxx where xxx is a three-letter identifier of the message data that follows. NMEA messages have a checksum, which allows detection of corrupted data transfers.

The Gotop GT-1010-MT supports the following NMEA-0183 messages: GGA, GLL, GSA, GSV, RMC and VTG

**Table 1: NMEA-0183 Output Messages**

NMEA Record	DESCRIPTION
GGA	Global positioning system fixed data
GLL	Geographic position—latitude/longitude
GSA	GNSS DOP and active satellites
GSV	GNSS satellites in view
RMC	Recommended minimum specific GNSS data
VTG	Course over ground and ground speed

### GGA-Global Positioning System Fixed Data

Table 2 contains the values of the following example:

\$GPGGA, 161229.487,3723.2475,N, 12158.3416,W, 1,07,1.0,9.0,M.0000\*18

**Table 2: GGA Data Format**

Name	Example	Units	Description
Message ID	\$GPGGA		GGA protocol header
UTC Position	161229.487		hhmmss.sss
Latitude	3723.2457		ddmm.mmmm
N/S indicator	N		N=north or S=south
Longitude	12158.3416		dddmm.mmmm
E/W Indicator	W		E=east or W=west
PositionFixIndicator	1		See Table 2-1
Satellites Used	07		Range 0 to 66
HDOP	1.0		Horizontal Dilution of Precision
MSL Altitude	9.0	meters	
Units	M	meters	
Geoids Separation		meters	
Units	M	meters	
Age of Diff.Corr.		second	Null fields when DGPS is not Used
Diff.Ref.Station ID	0000		
Checksum	*18		
<CR> <LF>			End of message termination

**Table 2-1: Position Fix Indicators**

Value	Description
0	Fix not available or invalid
1	GPS SPS Mode, fix valid



2	Differential GPS, SPS Mode, fix valid
3	GPS PPS Mode, fix valid

### GLL-Geographic Position – Latitude/Longitude

Table 3 contains the values of the following example:

\$GPGLL , 3723.2475, N,12158.3416, W,161229.487, A\*2C.

**Table 3: GLL Data Format**

Name	Example	Units	Description
Message ID	\$GPGLL		GLL protocol header
Latitude	3723.2475		ddmm.mmmm
N/S Indicator	N		N=north or S=south
Longitude	12158.3416		dddmm.mmmm
E/W Indicator	W		E=east or W=west
UTC Position	161229.487		hhmmss.sss
Status	A		A=data valid or V=data not valid
Checksum	*2C		
<CR> <LF>			End of message termination

### GSA-GNSS DOP and Active Satellites

Table 4 contains the values of the following example:

\$GPGSA , A, 3, 07, 02, 26,27, 09, 04,15, , , , , , 1.8,1.0,1.5\*33.

**Table 4: GSA Data Format**

Name	Example	Units	Description
Message	\$GPGSA		GSA protocol header
Mode 1	A		See Table 4-2
Mode 2	3		See Table 4-1

Satellite Used	07		Sv on Channel 1
Satellite Used	02		Sv on Channel 2
...	...		...
Satellite Used			Sv on Channel 66
PDOP	1.8		Position Dilution of Precision
HDOP	1.0		Horizontal Dilution of Precision
VDOP	1.5		Vertical Dilution of Precision
Checksum	*33		
<CR> <LF>			End of message termination

**Table 4-1: Mode 1**

Value	Description
1	Fix not available
2	2D
3	3D

**Table 4-2: Mode 2**

Value	Description
M	Manual-forced to operate in 2D or 3D mode
A	Automatic-allowed to automatically switch 2D/3D

## GSV-GNSS Satellites in View

Table 5 contains the values of the following example:

```
$GPGSV, 2, 1, 07, 07, 79,048, 42, 02, 51,062, 43, 26, 36,256, 42, 27, 27, 138,42*71
```

```
$GPGSV, 2, 2, 07, 09, 23,313, 42, 04, 19, 159, 41, 15,12,041, 42*41.
```

**Table 5: GSV Data Format**

Name	Example	Units	Description
Message ID	\$GPGSV		GSV protocol header
Number of Message	2		Range 1 to 3
Message Number	1		Range 1 to 3
Satellites in View	07		
Satellite ID	07		Channel 1(Range 1 to 66)
Elevation	79	degrees	Channel 1(Maximum 90)
Azinmuth	048	degrees	Channel 1(True, Range 0 to 359)
SNR(C/NO)	42	dBHz	Range 0 to 99,null when not tracking
...			...
Satellite ID	27		Channel 4(Range 1 to 66)
Elevation	27	degrees	Channel 4(Maximum 90)
Azimuth	138	degrees	Channel 4(True, Range 0 to 359)
SNR(C/NO)	42	dBHz	Range 0 to 99, null when not tracking
Checksum	*71		
<CR> <LF>			End of message termination

Depending on the number of satellites tracked multiple messages of GSV data may be required.

### RMC-Recommended Minimum Specific GNSS Data

Table 6 contains the values of the following example:

\$GPRMC, 161229.487, A, 3723.2475, N, 12158.3416, W, 0.13,309.62, 120598., \*10

**Table 6: RMC Data Format**

Name	Example	Units	Description
Message ID	\$GPRMC		RMC protocol header
UTS Position	161229.487		hhmmss.sss
Status	A		A=data valid or V=data not valid
Latitude	3723.2475		ddmm.mmmm
N/S Indicator	N		N=north or S=south
Longitude	12158.3416		dddmm.mmmm
E/W Indicator	W		E=east or W=west
Speed Over Ground	0.13	Knots	
Course Over	309.62	Degrees	True
Ground			
Date	120598		dummy
Magnetic variation		Degrees	E=east or W=west
Checksum	*10		
<CR> <LF>			End of message termination

### VTG-Course Over Ground and Ground Speed

Table 7 contains the values of the following example:

\$GPVTG, 309.62, T, M, 0.13, N, 0.2, K\*6E

**Table 7: VTG Data Format**

Name	Example	Units	Description
Message ID	\$GPVTG		VTG protocol header
Course	309.62	Degrees	Measured heading
Reference	T		True
Course		Degrees	Measured heading
Reference	M		Magnetic

Speed	0.13	Knots	Measured horizontal speed
Units	N		Knots
Speed	0.2	Km/hr	Measured horizontal speed
Units	K		Kilometer per hour
Checksum	*6E		
<CR> <LF>			End of message termination

### Manufacturing Process Recommendations

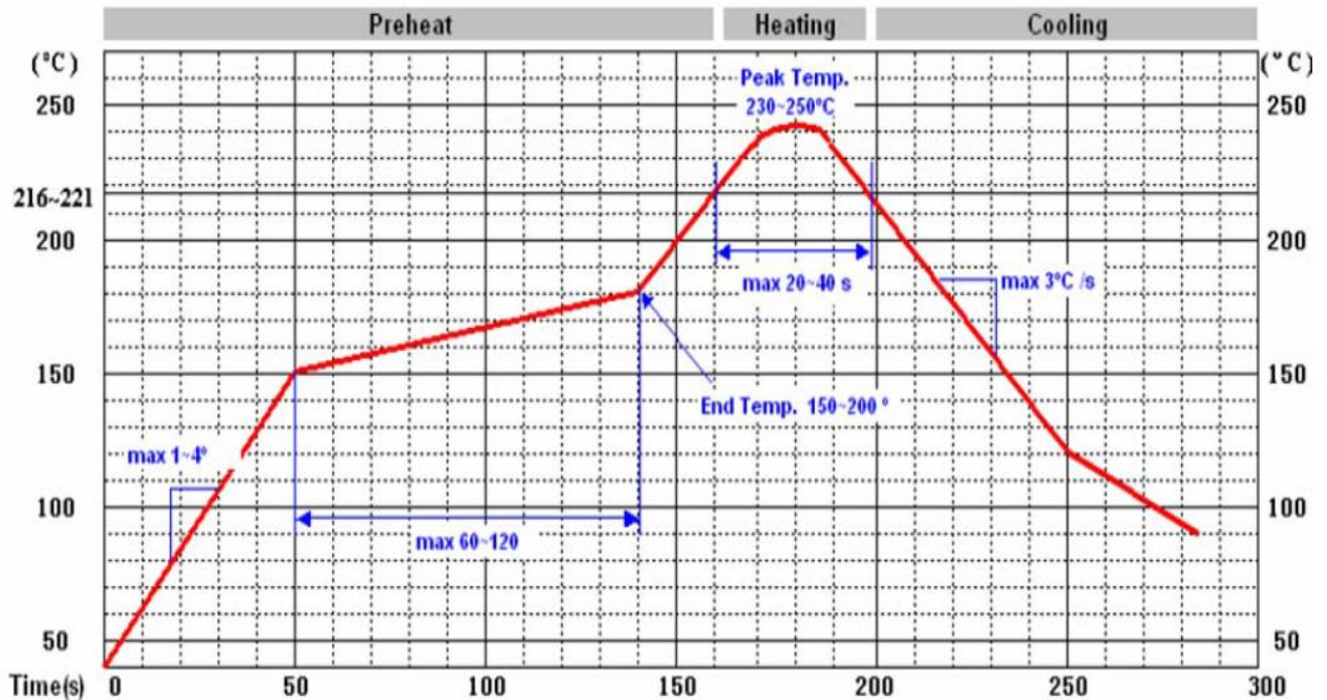

**Note:** The final soldering temperature chosen at the factory depends on additional external factors like choice of soldering paste, size, thickness and properties of the baseboard, etc. Exceeding the maximum soldering temperature in the recommended soldering profile may permanently damage the module.

©Copyright 2013 Gotop Technology Co., Ltd. All Right Reserved

The information contained herein is subject to change without notice.

### **Gotop Technology Co.,LTD**

Add:Room 603 Zhantao Technology Building,Minzhi Road,Xinniu Communnity,Minzhi Street,Baoan District,ShenZhen City China.

Phone: 13926505646

fax: 86-755-23804155

N 22° 32' 17", E 114° 07' 07"

<http://www.voosoo.cn>

Not to be reproduced in whole or part for any purpose without written permission of Gotop Technology Inc ('Gotop'). Information provided by Gotop is believed to be accurate and reliable. These materials are provided by Gotop as a service to its customers and may be used for informational purposes only. Gotop assumes no responsibility for errors or omissions in these materials, nor for its use. Gotop reserves the right to change specification at any time without notice.

These materials are provides 'as is' without warranty of any kind, either expressed or implied, relating to sale and/or use of Gotop products including liability or warranties relating to fitness for a particular purpose, consequential or incidental damages, merchantability, or infringement of any patent, copyright or other intellectual property right. Gotop further does not warrant the accuracy or completeness of the information, text, graphics or other items contained within these materials. Gotop shall not be liable for any special, indirect, incidental, or consequential damages, including without limitation, lost revenues or lost profits, which may result from the use of these materials.

Gotop products are not intended for use in medical, life-support devices, or applications involving potential risk of death, personal injury, or severe property damage in case of failure of the product.